



RALLYE DU MAROC



THE ESSENCE
OF RALLY RAID



2019

◀ RALLY GUIDE ▶



OFFICIAL SPONSOR



INSTITUTIONAL PARTNER



OFFICIAL SUPPLIER





◀ SOMMAIRE / SUMMARY ▶

◀ Programme du rallye / Rally program	3
◀ Plan général de Fès / Fez overview layout	4
◀ Plan du PC du rallye / Rally HQ layout (Hotel Marriott)	5
◀ Plan du Parc d'assistance / Service park layout (Complexe Sportif)	8
◀ Plan général du bivouac / Bivouac overview layout	10
◀ Timing & Kilométrages / Timing & Milage	11
◀ Carte du shakedown / Shakedown Map	12
◀ Road book du shakedown / Shakedown Map & Road book	13
◀ Lexique du Road book / Road book Lexicon	24
◀ Modèle de Road book / Road book Model	25



◀ PROGRAMME DU RALLYE / RALLY PROGRAM ▶

Mercredi 2 Octobre / Wednesday, October 2nd

- ◀ 8H00 Ouverture du parc d'assistance / Service Park opening

Jeudi 3 Octobre / Thursday, October 3rd

- ◀ 7H30 Ouverture des contrôles administratifs / Administrative checks open
- ◀ 9H00 Ouverture des contrôles techniques / Scrutineering opens
- ◀ 14H00 1^{ère} formation médicale FIA / 1st FIA Medical Training
- ◀ 15H15 2^{ème} formation médicale FIA / 2nd FIA Medical training
- ◀ 16H30 3^{ème} formation médicale FIA / 3rd FIA Medical training
- ◀ 18H00 Conférence de presse / Press conference
- ◀ 21H00 Briefing général pour la 1^{ère} étape / General and 1st stage briefing

Vendredi 4 octobre / Friday, October 4th

- ◀ 8H00 Ouverture des contrôles techniques / Scrutineering opens
- ◀ 13H00 Fermeture des contrôles techniques / Scrutineering closes
- ◀ 13H55 Première moto au départ du prologue / Start of 1st bike at prologue
- ◀ 18H00 Cérémonie d'ordre de départ Moto / Motorcycle start order ceremony
- ◀ 19H00 Publication des ordres de départ 1^{ère} étape / Publication of start order for 1st stage

Mercredi 9 octobre / Wednesday, October 9th

- ◀ 21H30 Remise des prix officielle à l'hotel Marriott / Official prize giving at Marriott Hotel



PLAN GÉNÉRAL DE FÈS / FEZ OVERVIEW LAYOUT

LEGENDES & SYMBOLES / LEGENDS & SYMBOLS

- | | | | |
|--|---|--|---|
| | VILLE ÉTAPE
CITY STAGE | | CONTRÔLE HORAIRE
TIME CONTROL |
| | STATION SERVICE
PETROL STATION | | PARC ASSISTANCE OU BIVOUAC
SERVICE PARK OR BIVOUAC |
| | HÉLICOPTÈRE SÉCURITÉ/MÉDICAL
SAFETY/MEDICAL HELICOPTER | | HÉLICOPTÈRE MEDICAL
SAFETY/MEDICAL |
| | AÉROPORT
AIRPORT | | HÔPITAL
HOSPITAL |
| | LIAISON CONCURRENTS
COMPETITOR ROAD SECTION | | PARCOURS PC RALLYE ↔ PA
RALLY HQ ↔ SP ROUTE |
| | ROUTE NON EMPRUNTÉE
ROAD NOT USED | | PISTE D'ACCÈS A L'ES
ACCESS TRACK TO SS |

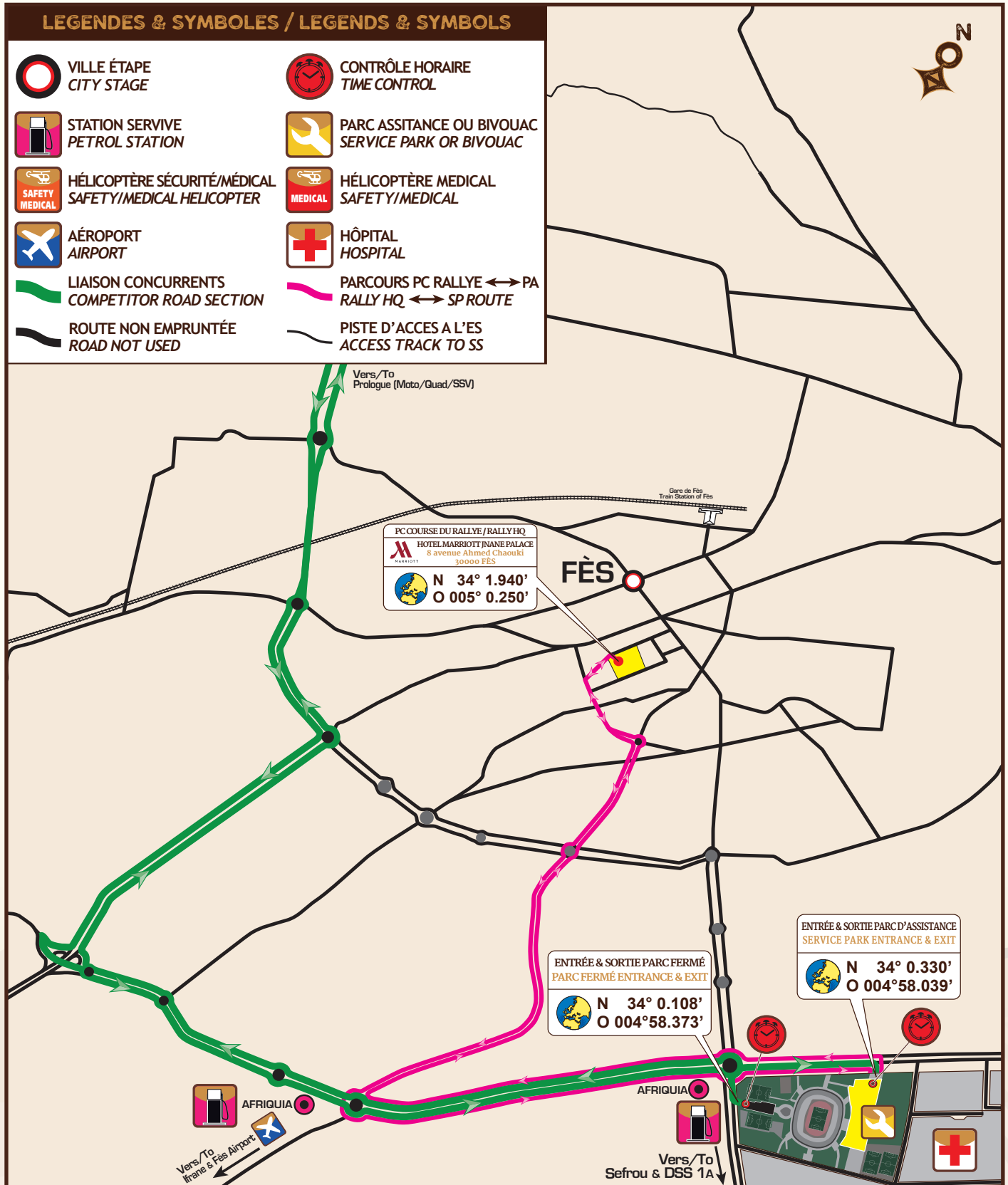

RALLYE DU MAROC

AUX SOURCES
DU RALLYE-RAID



odc
ORGANISATION
DAVIDCASTERA
EVENTS

PLAN DU PC DU RALLYE / RALLY HQ LAYOUT

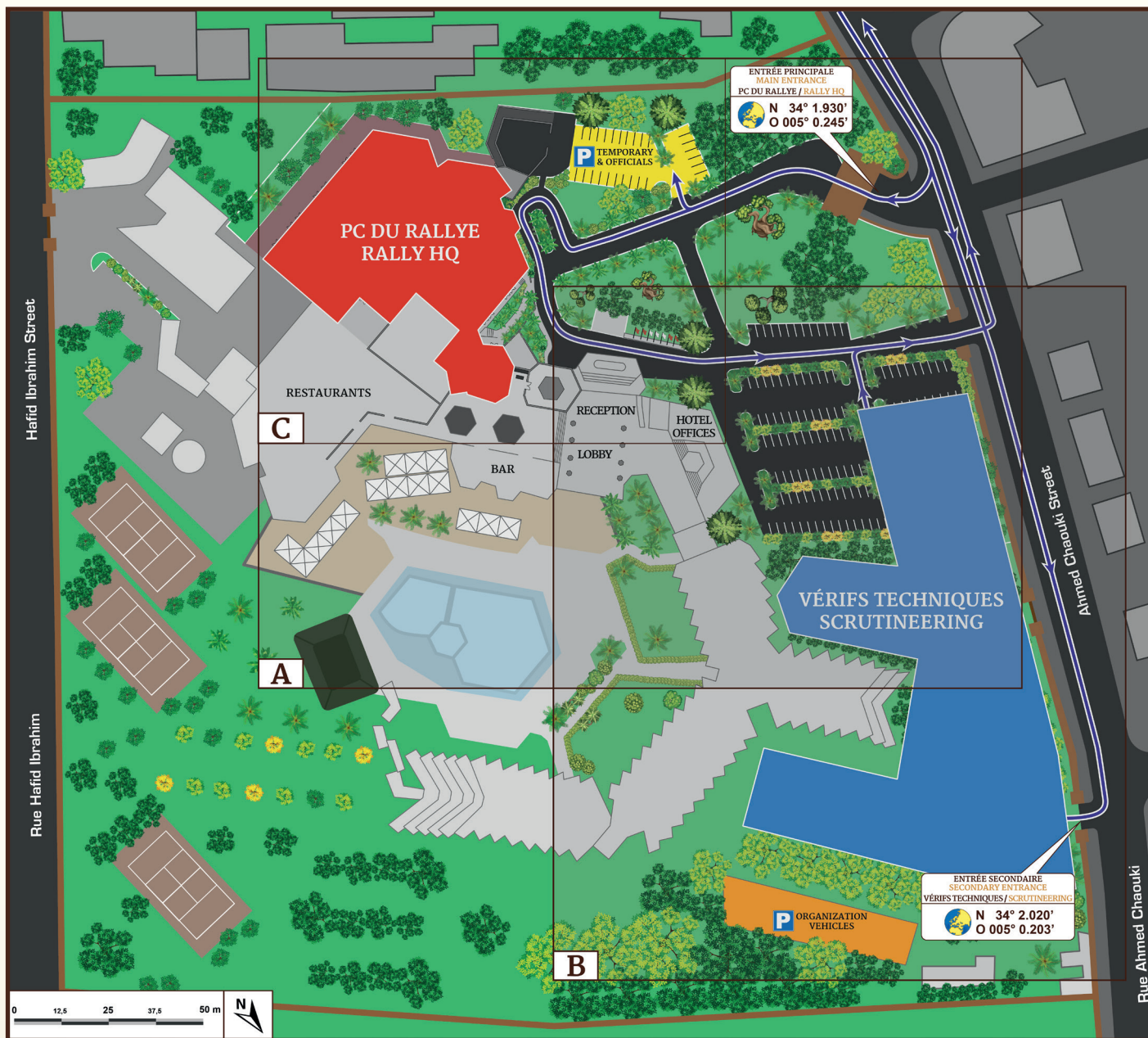



PLAN DU PC DU RALLYE / RALLY HQ LAYOUT



RALLYE DU MAROC

AUX SOURCES
DU RALLYE-RAID



odc
ORGANISATION
DAVIDCASTERA
EVENTS

PLAN DU PC DU RALLYE / RALLY HQ LAYOUT

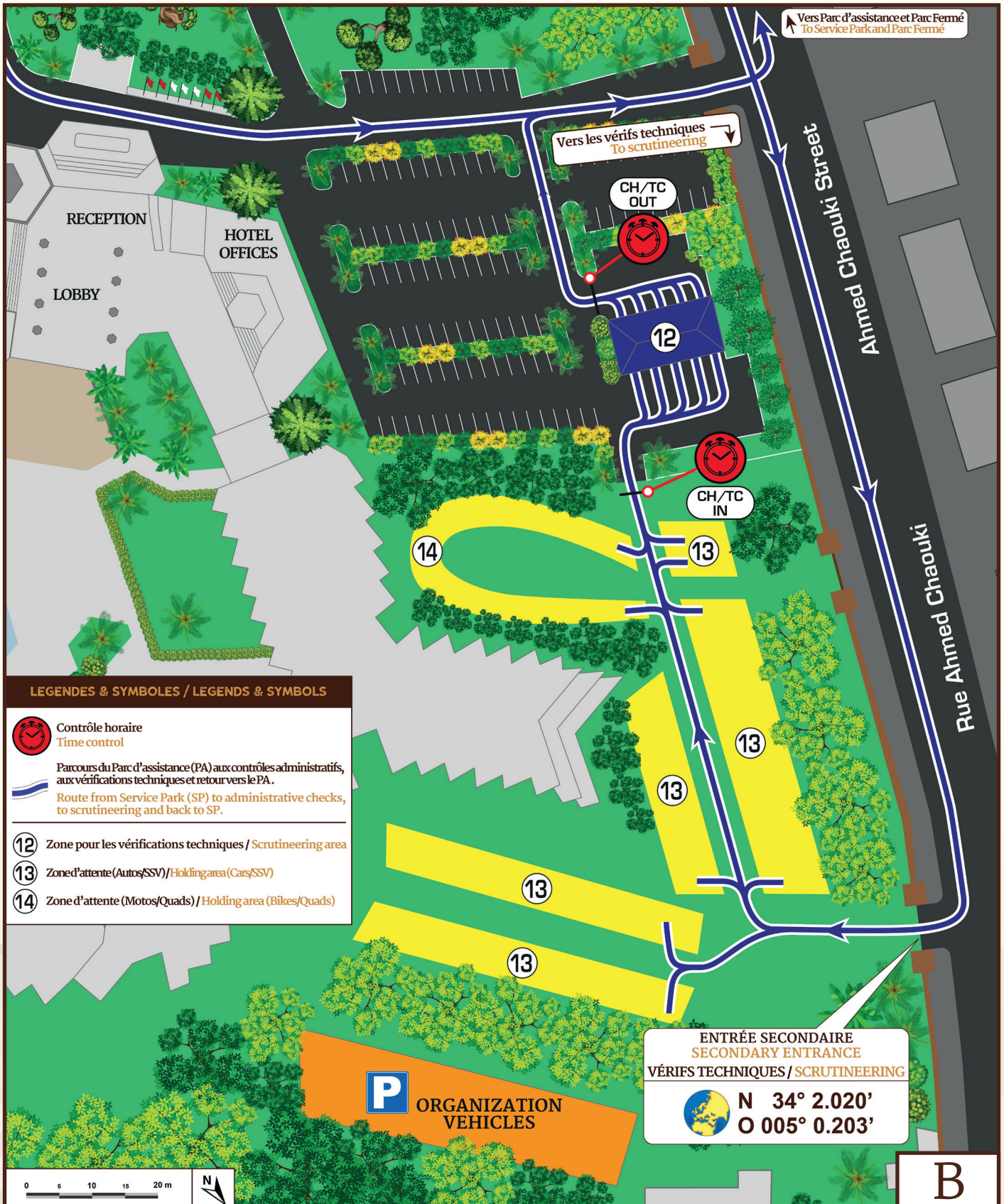



PLAN DU PC DU RALLYE / RALLY HQ LAYOUT

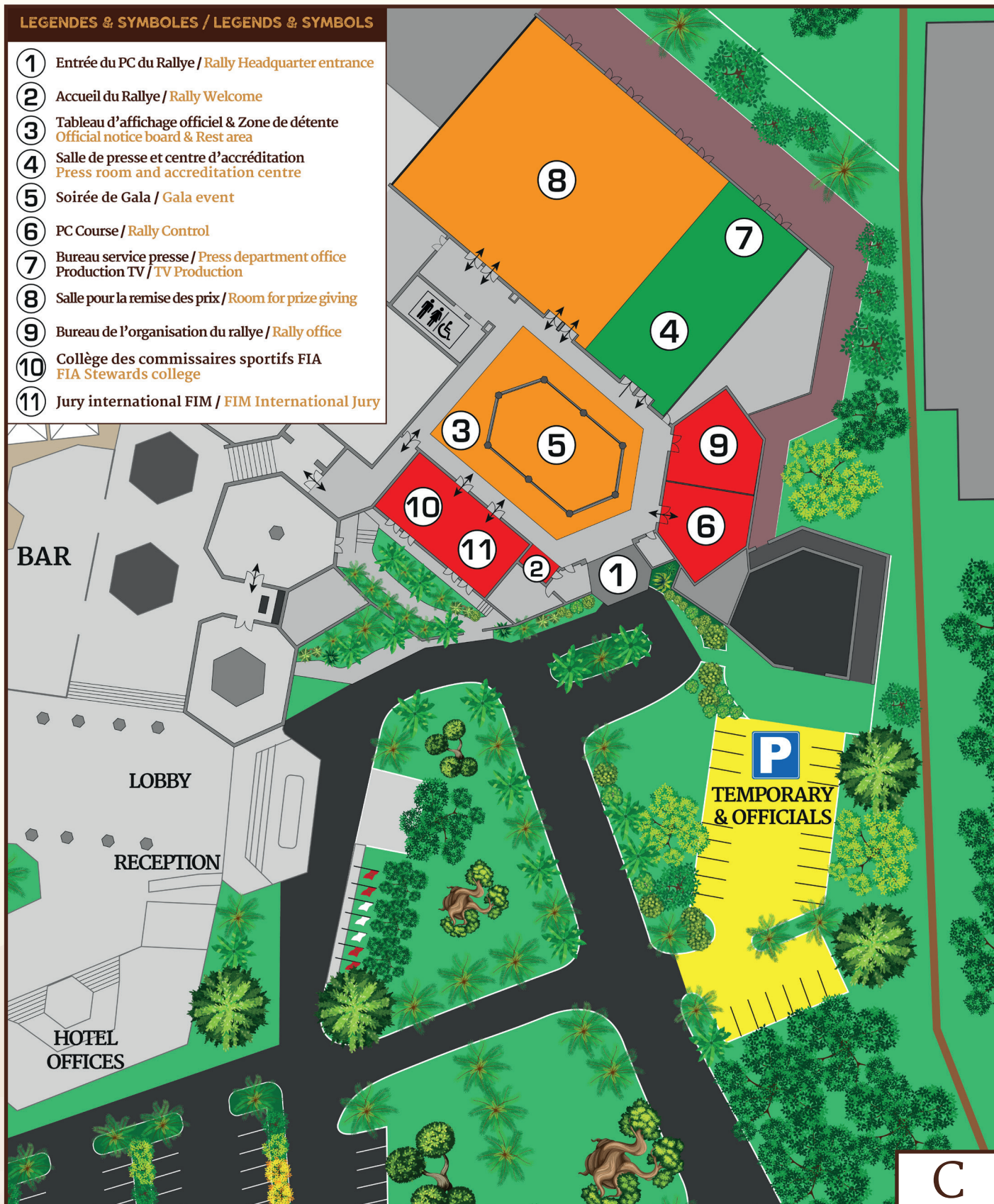

PLAN DU PARC D'ASSISTANCE / SERVICE PARK LAYOUT

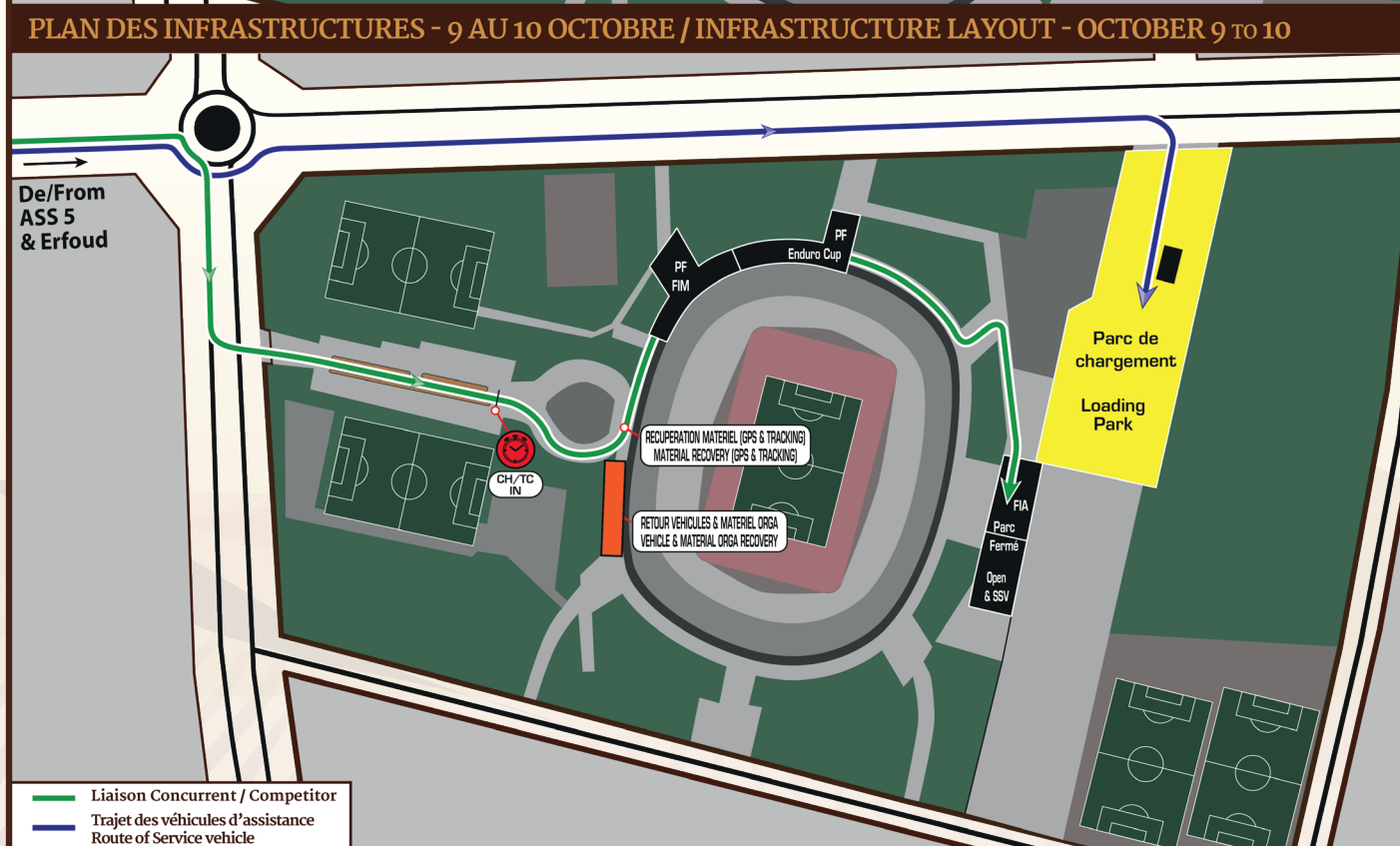
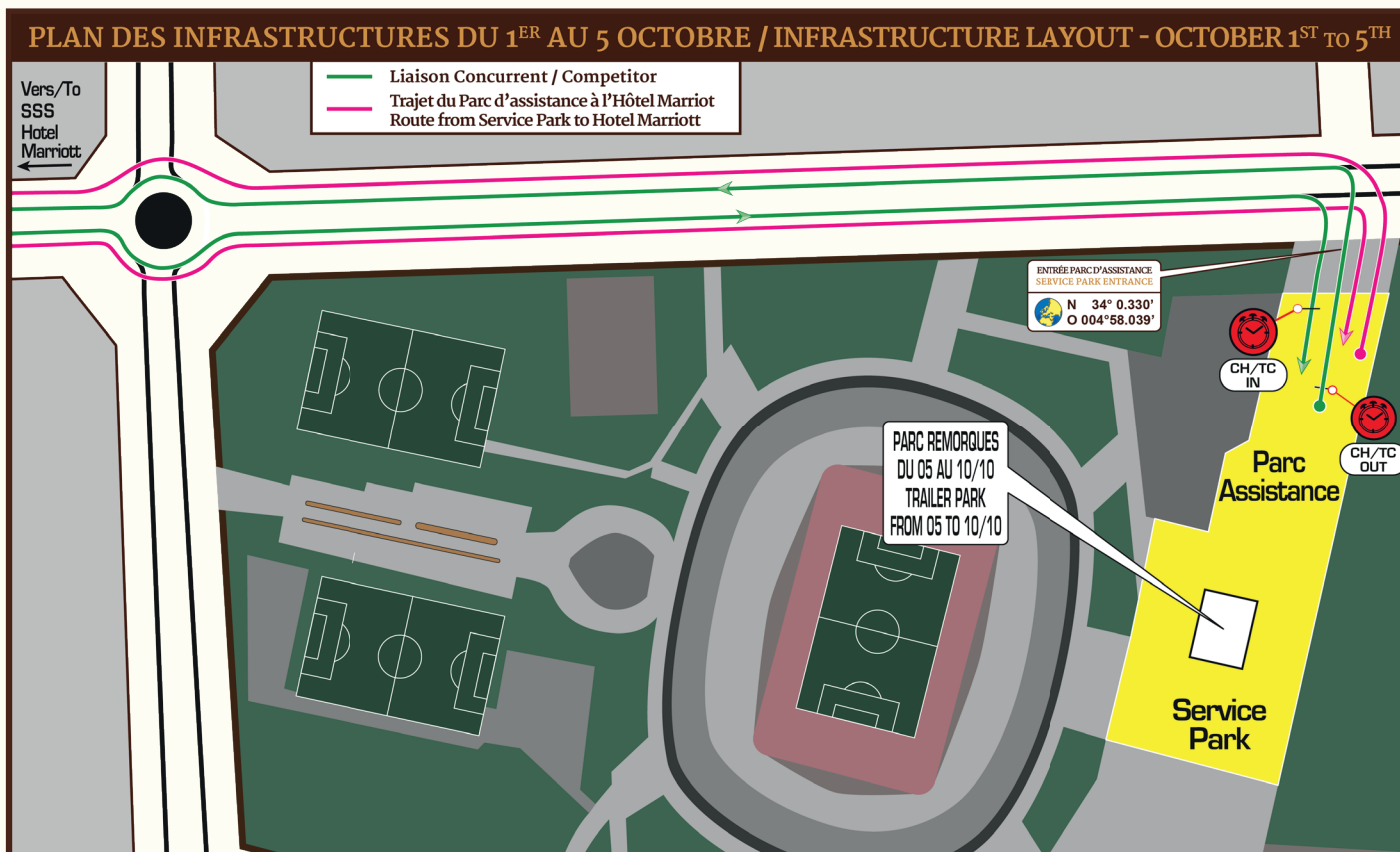



◀ PLAN GÉNÉRAL DU BIVOUAC / BIVOUAC OVERVIEW LAYOUT ▶

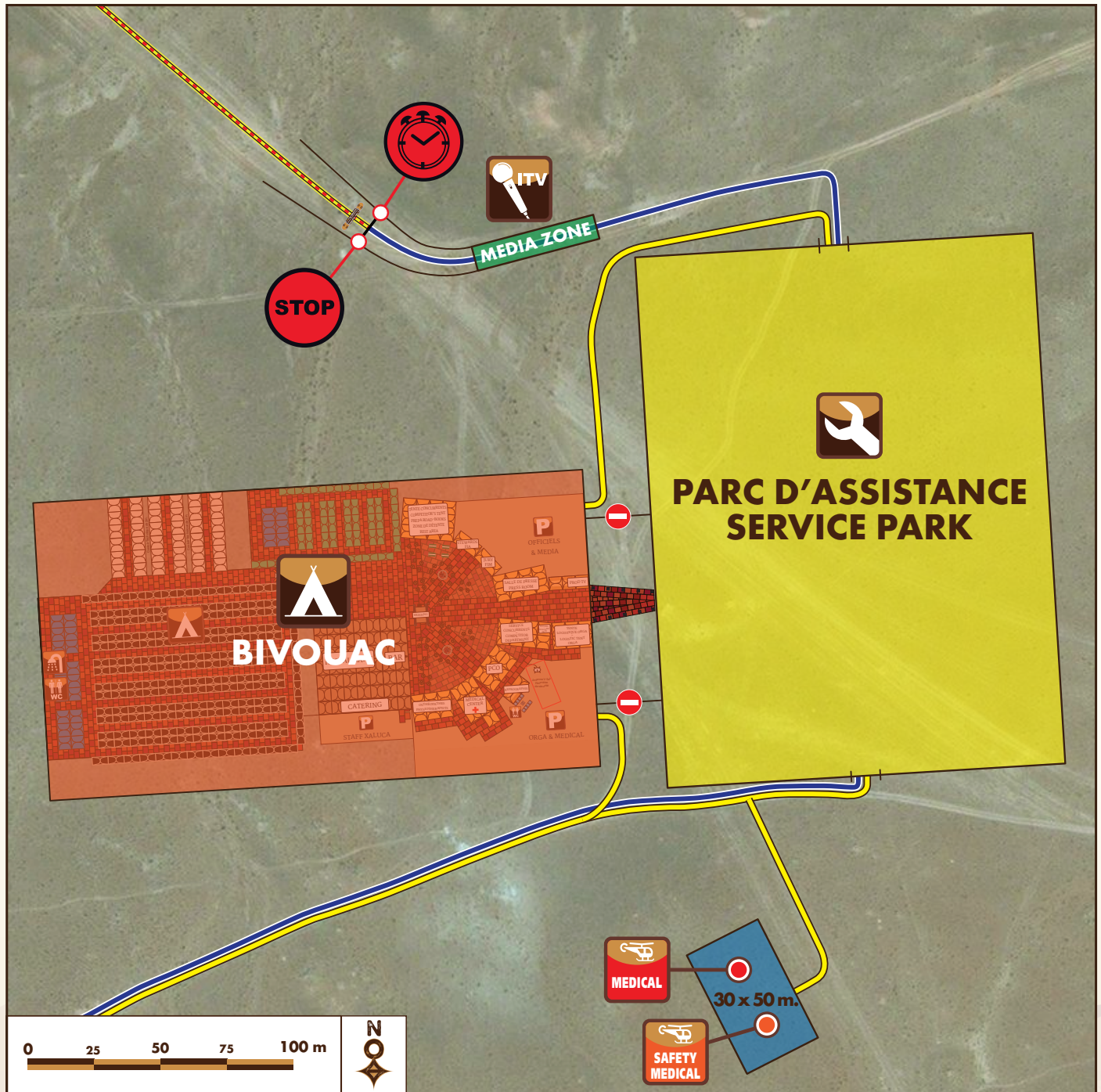



◀ TIMING & KILOMÉTRAGES / TIMING & MILAGE ▶

MOTO QUAD FIM

Stage	Date	Startf	Finish	START FROM BIVOUAC		SPECIAL START		SPECIAL FINISH		ESTIMATED TIME ROAD SECTION ARRIVAL	
				1st BIKE	Last CCR	1st BIKE	Last CCR	1st BIKE	Last CCR	1st BIKE	Last CCR
0	4/10	FES	FES	13:00	14:09	13:55	15:04	14:01	15:12	15:01	16:12
1	5/10	FES	ERFOUD	06:00	07:09	07:50	08:59	13:38	15:02	13:38	15:02
2	6/10	ERFOUD	ERFOUD	06:00	07:09	07:20	08:29	11:52	13:52	11:52	13:52
3	7/10	ERFOUD	ERFOUD	–	–	07:20	08:29	14:26	15:36	14:26	15:36
4	8/10	ERFOUD	ERFOUD	06:00	07:09	07:30	08:39	11:23	13:39	12:23	13:39
5	9/10	ERFOUD	FES	05:30	06:39	09:05	10:14	11h11	12h59	12:41	13:59

ENDURO CUP

Stage	Date	Start	Finish	START FROM BIVOUAC		SPECIAL START		SPECIAL FINISH		ESTIMATED TIME ROAD SECTION ARRIVAL	
				1st BIKE EC	Last CCR	1st BIKE EC	Last CCR	1st BIKE EC	Last CCR	1st BIKE EC	Last CCR
0	4/10	FES	FES	14:10	14:27	15:05	15:22	15:13	15:32	15:13	16:32
1	5/10	FES	ERFOUD	08:22	08:58	10:12	10:48	16:20	18:18	16:20	18:18
2	6/10	ERFOUD	ERFOUD	07:10	07:27	08:30	08:47	12:50	15:49	14:00	16:59
3	7/10	ERFOUD	ERFOUD	–	–	10:06	10:42	14:36	16:30	14:36	16:30
4	8/10	ERFOUD	ERFOUD	07:10	07:27	08:40	08:57	12:19	14:42	13:49	16:12
5	9/10	ERFOUD	FES	07:52	08:28	11:27	12:03	14:03	16:18	15:33	17:48

SSV

Stage	Date	Startf	Finish	START FROM BIVOUAC		SPECIAL START		SPECIAL FINISH		ESTIMATED TIME ROAD SECTION ARRIVAL	
				1st SSV	Last CCR	1st SSV	Last CCR	1st SSV	Last CCR	1st SSV	Last CCR
0	4/10	FES	FES	14:37	15:15	15:32	16:10	15:40	16:20	16:40	17:20
1	5/10	FES	ERFOUD	09:13	09:51	11:03	11:41	17:21	19:26	17:21	19:26
2	6/10	ERFOUD	ERFOUD	07:42	08:20	09:02	09:40	13:52	17:40	13:52	17:40
3	7/10	ERFOUD	ERFOUD	–	–	10:57	11:35	15:45	20:05	15:45	20:05
4	8/10	ERFOUD	ERFOUD	07:42	08:20	09:12	09:50	14:14	18:50	15:44	20:20
5	9/10	ERFOUD	FES	08:43	09:21	12:18	12:56	14:53	17:11	16:23	18:41



◀ TIMING & KILOMÉTRAGES / TIMING & MILAGE ▶

AUTO FIA

Stage	Date	Startf	Finish	START FROM BIVOUAC		SPECIAL START		SPECIAL FINISH		ESTIMATED TIME ROAD SECTION ARRIVAL	
				1st CAR FIA	Last CCR	1st CAR FIA	Last CCR	1st CAR FIA	Last CCR	1st CAR FIA	Last CCR
0	4/10	FES	FES	–	–	–	–	–	–	–	–
1	5/10	FES	ERFOUD	07:24	08:07	09:14	09:57	15:02	16:12	15:02	16:12
2	6/10	ERFOUD	ERFOUD	08:50	09:33	10:10	10:53	14:42	16:53	14:42	16:53
3	7/10	ERFOUD	ERFOUD	–	–	08:44	09:27	15:51	17:53	15:51	17:53
4	8/10	ERFOUD	ERFOUD	08:50	09:33	10:20	11:03	14:13	16:03	15:13	17:03
5	9/10	ERFOUD	FES	06:54	07:37	10:29	11:12	12:35	14:00	14:05	15:30

AUTO OPEN

Stage	Date	Startf	Finish	START FROM BIVOUAC		SPECIAL START		SPECIAL FINISH		ESTIMATED TIME ROAD SECTION ARRIVAL	
				1st CAR OPEN	Last CCR OPEN	1st CAR OPEN	Last CCR OPEN	1st CAR OPEN	Last CCR OPEN	1st CAR OPEN	Last CCR OPEN
0	4/10	FES	FES	–	–	–	–	–	–	–	–
1	5/10	FES	ERFOUD	10:01	10:15	11:51	12:05	18:07	21:15	18:07	21:15
2	6/10	ERFOUD	ERFOUD	09:43	09:57	11:03	11:17	15:23	19:20	16:33	20:30
3	7/10	ERFOUD	ERFOUD	–	–	09:37	09:51	14:16	15:51	14:16	15:51
4	8/10	ERFOUD	ERFOUD	09:43	09:57	11:13	11:27	15:39	20:27	17:09	21:57
5	9/10	ERFOUD	FES	09:21	09:35	12:56	13:10	15:44	17:25	17:14	18:55



◀ CARTE DU SHAKEDOWN / SHAKEDOWN MAP ▶

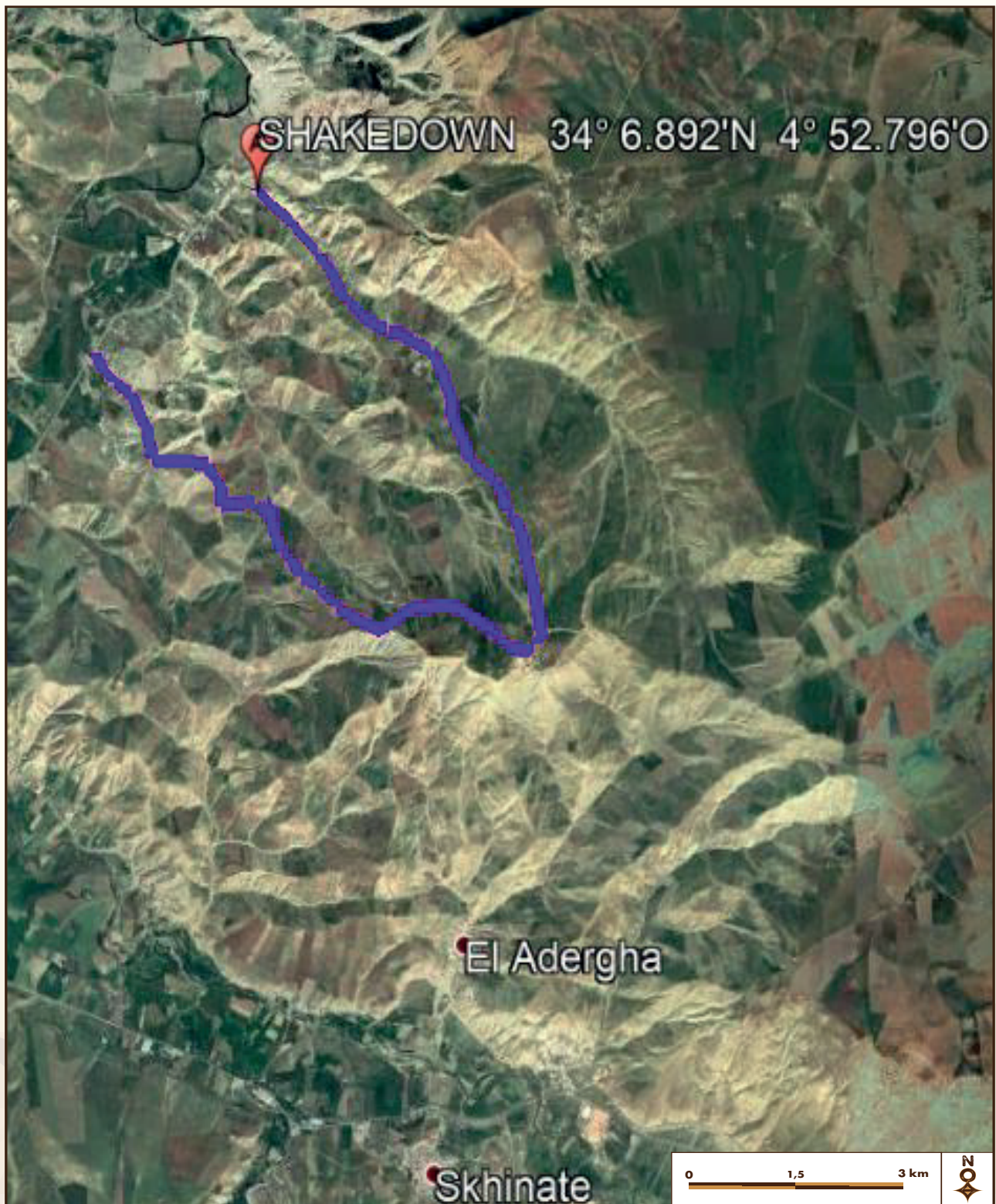

Piste ouverte avec autorisation des autorités locales, réservée pour le shakedown des concurrents.
Chaque concurrent sera responsable de la sécurité lors de son utilisation.
Open track with authorized by local authorities, booked for the competitor shakedown.
Each competitor will be responsible for safety when using it.

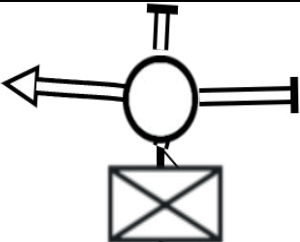
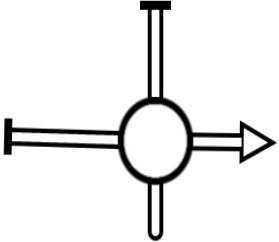
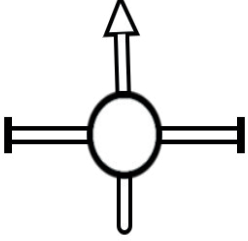
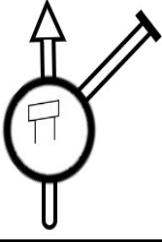
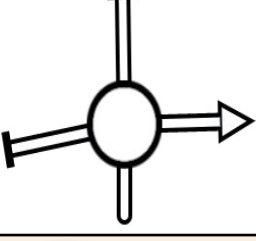

◀ ROAD BOOK DU SHAKEDOWN / SHAKEDOWN ROAD BOOK ▶

PAGE 1	LIAISON 1 - SHAKEDOWN		KM TOTAL : 22.99
0,00			
1	0,00		
0,69			
2	0,69		
1,55			
3	0,86		
2,04			
4	0,49		
2,87			BMCE
5	0,83		
PROXIMA NOTA PROCH NOTE NEXT NOTE	0,42		



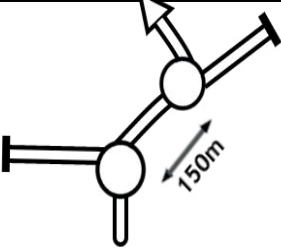
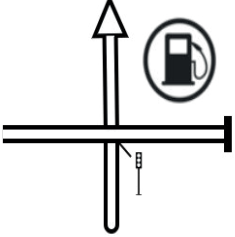
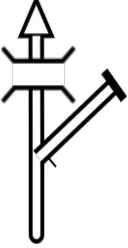
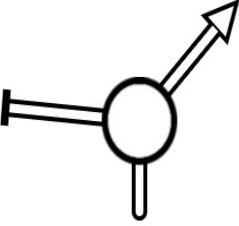
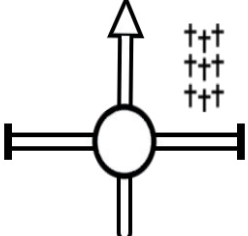

◀ ROAD BOOK DU SHAKEDOWN / SHAKEDOWN ROAD BOOK ▶

PAGE 2	LIAISON 1 - SHAKEDOWN	KM TOTAL : 22.99
3,29		
6 0,42		
4,12		
7 0,83		
6,23		
8 2,11		
7,55		
9 1,32		
8,53		
10 0,98		
PROXIMA NOTA PROCH NOTE NEXT NOTE	0,67	



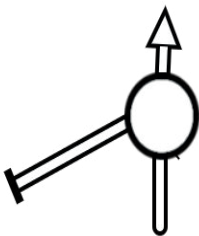

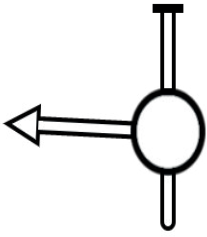
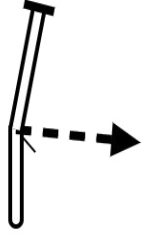
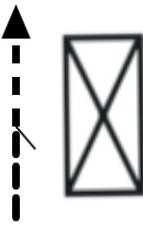

◀ ROAD BOOK DU SHAKEDOWN / SHAKEDOWN ROAD BOOK ▶

PAGE 3	LIAISON 1 - SHAKEDOWN	KM TOTAL : 22.99
9,20		
11 0,67		
11,46		TDSRP
12 2,26		
13,46		
13 2,00		
22,82		±V
14 9,36		
22,99		0000 Reset
0,00		
15 0,17		

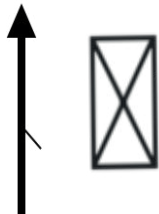



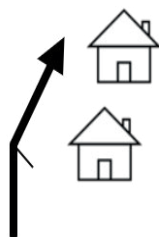



◀ ROAD BOOK DU SHAKEDOWN / SHAKEDOWN ROAD BOOK ▶

PAGE 1	SHAKEDOWN		KM TOTAL : 11.43
0,00			
1	0,00		
0,24			
2	0,24		
0,49			!! Sinueux
3	0,25		
1,79			
4	1,30		
2,34			RALENTIR
5	0,55		
PROXIMA NOTA PROCH NOTE NEXT NOTE	0,21		

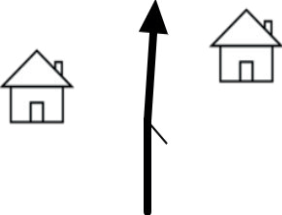

◀ ROAD BOOK DU SHAKEDOWN / SHAKEDOWN ROAD BOOK ▶

PAGE 2	SHAKEDOWN		KM TOTAL : 11.43
2,55			
6	0,21		
4,02			
7	1,47		
4,86			 PUITS
8	0,84		
5,31			RALENTIR
9	0,45		
5,46			 PEU VISIBLE
10	0,15		
PROXIMA NOTA PROCH NOTE NEXT NOTE	0,20		



◀ ROAD BOOK DU SHAKEDOWN / SHAKEDOWN ROAD BOOK ▶

PAGE 3	SHAKEDOWN	KM TOTAL : 11.43
5,66		
11 0,20		
6,33		
12 0,67		
7,07		
13 0,74		
8,73		
14 1,66		
9,05		
15 0,32		
PROXIMA NOTA PROCH NOTE NEXT NOTE	0,23	



◀ ROAD BOOK DU SHAKEDOWN / SHAKEDOWN ROAD BOOK ▶

PAGE 4	SHAKEDOWN		KM TOTAL : 11.43
9,28			
16	0,23		
9,44			
17	0,16		
9,70			
18	0,26		
10,25			
19	0,55		
10,62			
20	0,37		
PROXIMA NOTA PROCH NOTE NEXT NOTE	0,30		



◀ ROAD BOOK DU SHAKEDOWN / SHAKEDOWN ROAD BOOK ▶

PAGE 5	SHAKEDOWN		KM TOTAL : 11.43
10,92			
11,43			
11 Km	22 Waypoints	11 Km Fuel Range	
Start: N8, Fes-Medina, Fez-Meknès, Maroc		Finish: N8, Moulay Yacoub Province, Fez-Meknès, Maroc	



◀ ROAD BOOK DU SHAKEDOWN / SHAKEDOWN ROAD BOOK ▶

PAGE 1	L2-CHECKDOWN		KM TOTAL : 20.63
0,00			
1	0,00		
6,93			FES
2	6,93		
9,80			
3	2,87		
10,07			FES
4	0,27		
10,58			
5	0,51		
PROXIMA NOTA PROCH NOTE NEXT NOTE	0,63		



◀ ROAD BOOK DU SHAKEDOWN / SHAKEDOWN ROAD BOOK ▶

PAGE 2	L2-CHECKDOWN		KM TOTAL : 20.63
11,21			
6	0,63		
11,79			
7	0,58		
12,94		±V	
8	1,15		
16,37			
9	3,43		
17,05			
10	0,68		
PROXIMA NOTA PROCH NOTE NEXT NOTE	0,55		



◀ ROAD BOOK DU SHAKEDOWN / SHAKEDOWN ROAD BOOK ▶

PAGE 3	L2-CHECKDOWN		KM TOTAL : 20.63
17,60			
11	0,55		
18,46			
12	0,86		
18,97			
13	0,51		
19,84			
14	0,87		
20,63			PARC
15	0,79		

LEXIQUE DU ROAD BOOK / ROAD BOOK LEXICON

PISTES / TRACKS / PISTAS			
	ROUTE GOODWIN	THIRIAC ROAD	RUTA A SRAJLINDA
RO	ROUTE	ROAD	RUTA
	ROUTE avec séparateur central	DUAL CARRIAGEWAY	DOBLE CALZADA
	PISTE	GRAVEL TRACK	PISTA
	HORS PISTE	OFF TRACK	FUERA DE PISTA
	TRACKS	TRACKS	TRACAS
P	PISTE	GRAVEL TRACK	PISTA
G^D	GRAND	BIG	GRANDE
P^T	PETIT	SMALL	PEQUEÑO
Gd P	GRANDE PISTE	LARGE TRACK	PISTA GRANDE
PS	PISTE Sinueuse	WINDING TRACK	PISTA SINUOSA
PPS	PISTE PRINCIPALE Sinueuse	WINDING MAIN TRACK	PISTA PRINCIPAL SINUOSA
PP	PISTE PRINCIPALE	MAIN TRACK	PISTA PRINCIPAL
Q^T PP	QUITTER PISTE PRINCIPALE	LEAVE MAIN TRACK	DEJAR PISTA PRINCIPAL
P//	PISTES PARALLELES	PARALLEL TRACKS	PISTAS PARALELAS
HP	HORS PISTE	OFF ROAD	FUERA DE PISTA
HP	HORS PISTE INTERET	OFF ROAD INTERESTING	FUERA DE PISTA INTERESANTE
SECURITE / SAFETY / SEGURIDAD			
	ATTENTION 1	DANGER 1	PELIGRO 1
	DANGER 2	DANGER 2	PELIGRO 2
	GROS DANGER 3	DANGER 3	PELIGRO 3
	DEBUT DE ZONE VITESSE 30	START OF SPEED LIMIT	INICIO DE ZONA DE VITESSE 30
	Limite de VITESSE	SPEED LIMIT	Limite de VELOCIDAD
	FIN DE ZONE VITESSE 30	END OF SPEED LIMIT	FIN DE ZONA DE VITESSE 30
	STOP	STOP	STOP
	WAYPOINT MARQUE	WAYPOINT MARKED	WAYPOINT OCULTO
	WAYPOINT ECLIPSE	WAYPOINT ECLIPSE	WAYPOINT ECLIPSE
	WAYPOINT SECURITE	WAYPOINT SAFETY	WAYPOINT SEGURIDAD
	WAYPOINT CACHE	WAYPOINT HIDDEN	WAYPOINT OCULTO
	DISTANCE	DISTANCE	DISTANCIA
	CONTROLE DE PASSAGE	PASSAGE CONTROL	CONTROL DE PADO
	POINT RAVITAILLEMENT	REFUELLING POINT	PUNTO DE REPOSTAJE
CPs	CP LIAISON SECURITE	ROAD SECTION SAFETY FC	CP SEGURIDAD SECCION
ZONES / AREAS / ZONAS			
	DEPART	START	LARGADA
DSS	DEPART SECTEUR SELECTIF	START OF SELECTIVE SECTION	LARGADA SECTOR SELECTIVO
	ARRIVEE	FINISH	LLEGADA
ASS	ARRIVEE SECTEUR SELECTIF	FINISH OF SELECTIVE SECTION	LLEGADA SECTOR SELECTIVO
	CONTROL HORAIRE	TIME CONTROL	CONTROL HORARIO
	CHRONO	CLOCK	CRONOMETRAJE
NEU.IN	DEBUT NEUTRALISATION	START NEUTRALISATION	INICIO NEUTRALIZACION
NEU.OUT	FIN NEUTRALISATION	END OF NEUTRALISATION	FIN NEUTRALIZACION
	DEBUT ZONE D'ASSISTANCE	START OF SERVICE AREA	COMENZO DE ZONA DE ASISTENCIA
	FIN ZONE D'ASSISTANCE	FINISH OF SERVICE AREA	FIN DE ZONA DE ASISTENCIA
	VILLAGE	VILLAGE	PUEBLO
	BIVOUAC	CAMP	CAMPAMENTO
	AREA RESTRICTIVE	RESTRICTED AREA	AREA RESTRICTIVA
	STATION ESSENCE	PETROL STATION	GASOLINERA
SPECIFICITES / SPECIFICITIES / ESPECIFICIDADES			
	SOMMET	SUMMIT	CUMBRE
	CUVETTE	DIP	BAGEN
	BOSSE	BUMP	LOBADA
	COMPRESSION	COMPRESSION	COMPRESION
	SAIGNEE	DITCH	CORTE
	ROCKER	STEP	CORTE ABISPTO
	MARCHE EN DESCENTE	STEP DOWN	DESCENSO EN ESCALON
	MARCHE EN MONTEE	STEP UP	SUBIDA EN ESCALON
	TROU EFFONDRE	HOLE COLLAPSE	DEBARRIBE
	OMBRE	RIT	RODADA
MER	MER	SEA	MAR
	ONDULATION BOSSELLE	UNDULATION	ONDULACION
	ONDULATION CASSEE	UNDULATION BROKEN	ONDULACION ROTA
	SUR PONT SOUS PONT	ABOVE BRIDGE UNDER BRIDGE	ENCIMERADEJO DE PUNTE
	EAU	WATER	AGUA
	TROU	HOLE	HUECO
	CAIRN	CAIRN	MOLON
GV	GRAVIER	GRAVEL	TERRA
	CAILLOUX	ROCKS	PIEDRAS
CX	CAILLOUX	ROCKS	PIEDRAS
EMP	EMPIERRE	ROCKY	PIEDREGOSO
	PLATEAU	PLAIN	LLANURA
SA	SABLE	SAND	ARENA
	LANGUE DE SABLE	SAND SPIT	BANCO DE ARENA
	DUNES	DUNES	DUNAS
DNs	DUNES	DUNES	DUNAS
DNT	DUNETTE	SMALL DUNE	DUNA PEQUEÑA
	DUNE CASSEE	BROKEN DUNE	DUNA ROTA
	HERBE DE CHAMBEAU	CAMEL GRASS	HERBA DE CAMELLO
ORN	ORMERE	RUT	RODADA
	ARBRE	TREE	ARBOL
	PALME	PALM TREE	PALMERA
	ARBUSTE	SHRUB	ARBUSTO
	HERBES	TALL GRASS	HERBAS
VG	VEGETATION	VEGETATION	VEGETACION
	MONTAGNE	MOUNTAIN	MONTAÑA
RIO	RIVIERE	RIVER	RIO
	CUVETTE DANS DUNES	BIG BOWL IN DUNES	POZO DENTRO DUNAS
	INCLINAISON LATERALE	LATERAL INCLINATION	INCLINACION LATERAL
EFF	EFFONDRE	COLLAPSED	DEBARRIBE
MVS	MAUVAIS	BAD	HALO
S	SINEUX	TWISTY	SINOSO
S	SINEUX EN DESCENTE	TWISTY DOWN	SINOSO DESCENSO
SER	SERRE	TIGHT	QUE CIERRA
Moy	MOYEN	AVERAGE	MEDIO
CAL	CALCULE	CALCULATED	CALCULADO
OBLIC	OBLIQUE	OBLIQUO	OBLICUO
NBX	NOMBREUX	MANY	MUCHOS
E3	ETROIT	NARROW	ANGOSTO
DEF	DEFONCE	DAMAGE	DEBARRIBE
	FULCRUM BETON	WATER IN CONCRETE	AGUA EN HORMIGON
	BETON	CONCRETE	HORMIGON
ELEMENTS / ELEMENTS / ELEMENTOS			
	MAISON	HOUSE	CASA
	BATIMENTS	BUILDINGS	EDIFICIOS
	EGLISE	CHURCH	IGLESIA
MOUNT.	MONTAGNE	MOUNTAIN	MONTAÑA
LONG.	LONGER	FOLLOW / ALONG	SEGUIR / A LO LARGO
	OMETIERE	CEMETERY	CEMENTERO
	MONUMENT	MONUMENT	MONUMENTO
	FORT	FORT	FUERTE
	BORNES	KILOMETRE MARKER	MARCADOR DE KILOMETRAJE
	PIT	BARREL	TAMBOR
	PIPELINE	PIPELINE	CANALIZACION
	VOIE FERREE	RAILROAD	FERROCARRIL
	PUIT	WELL	POZO
	TUNNEL	TUNNEL	TUNEL
	MURET EN PIERRE	STONE WALL	MURO DE PIEDRA
	MURET	LOW WALL	MURO
	CLOTURE	FENCE	ALAMBRE
	PORTAIL BARRIERE	GATE BARRIER	TRANQUERA
	PASSAGE CANADIEN	CATTLE GRID	PASO CANADIENSE
	PNEUATTACHE	TYRE	NEUMATICO
	CITERNES	WATER TANK	TANQUE DE AGUA
	RUINES	RUINS	RUINAS
	POTEAU POTELET	POST	POSTE SETAGUA
	POTEAU ELECTRIQUE	ELECTRIC POLE	POSTE ELECTRICO
	PYLONE ELECTRIQUE HAUTE TENSION	HIGH VOLTAGE TOWER	POSTE ELECTRICO ALTA TENSION
	ELECTRIQUE	ELECTRIC	ELECTRICO
	LIGNE ELECTRIQUE	ELECTRIC LINE	LINEA ELECTRICA
	ANTENNE	ANTENNA / MAST	ANTENA
	FIL BARBELE	BARBED WIRE FENCE	ALAMBRE DE PUA
DIRECTIONS / DIRECTIONS / DIRECCIONES			
	et à	et al.	and et...
AD	A DROITE	ON THE RIGHT	A LA DERECHA
AG	A GAUCHE	ON THE LEFT	A LA IZQUIERDA
D	DROITE	RIGHT	DERECHA
G	GAUCHE	LEFT	IZQUIERDA
PASS	PASSAGE	PASS	PASO
CANY	CANYON	CANYON	CANON
	DESCENTE	DOWNHILL	BAJADA
	VERS	TOWARDS	HACIA
	MONTEE	UPHILL	SUBIDA
BETW	ENTRE	BETWEEN	ENTRE
180°	CAP	BEARING	RUMBO (CAP)
DS	DANS	INTO	EN / ADENTRO
RLT	RALENTIR	SLOW DOWN	DESPACIO
RP	REPRISE REPASSE	TAKE AGAIN	RETORNAR
QT	QUITTER	LEAVE	DEJAR
TD	TOUT DROIT	KEEP STRAIGHT	DERECHO
SPP	SUIVRE PISTE PRINCIPALE	FOLLOW MAIN GRAVEL ROAD	SEGUIR PISTA PRINCIPAL
SRP	SUIVRE ROUTE PRINCIPALE	FOLLOW MAIN THIRIAC ROAD	SEGUIR RUTA PRINCIPAL
TJS	TOUJOURS	ALWAYS	SIEMPRE
	PLUS OU MOINS VISIBLE	MORE OR LESS VISIBLE	MAS MENOS VISIBLE
	MOINS VISIBLE	LESS VISIBLE	POCO VISIBLE
IMP	IMPERATIF	IMPERATIVE	IMPERATIVO
CONT.	CONTOURNER	GET AROUND	RODEAR
VAL.	VALLÉE	VALLEY	VALLE
G SER	SERREZ A DROITE	KEEP TO THE RIGHT	MANTENESE A LA DERECHA
D SER	SERREZ A GAUCHE	KEEP TO THE LEFT	MANTENESE A LA IZQUIERDA



◀ MODÈLE DE ROAD BOOK / ROAD BOOK MODEL ▶

1	/ Présentation RB V5 /		Km : 31,16
0,00	260 PP		NBX // ET à 300 M 295
0,00			
3,72			ET 40
3,72			
8,48			30
4,76	DZ		
8,72			30
0,24			1
8,97			
0,25	FZ		30

Next 3,41 **Danger 1**

◀ MODÈLE DE ROAD BOOK / ROAD BOOK MODEL ▶

2	/ Présentation RB V5 /	Km : 31,16
12,38		
3,41		
<u>13,62</u>		ET TDPP
1,24		
14,73		②
1,11 S		
15,64		ET HP DS OUED ③
0,91 M		
17,25		HP DS DN
1,61		

Next 0,53 **Danger 1**











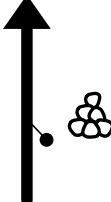

◀ MODÈLE DE ROAD BOOK / ROAD BOOK MODEL ▶

3	/ Présentation RB V5 /	Km : 31,16
17,78	<p>268 L2</p>	HP DS DN
0,53	C	4
18,60	<p>L3</p>	HP DS DN
0,82	180	
18,94	<p>80 MVS</p>	END DN
0,34	S	5
21,10	<p>50m 05 Moy 300 m</p>	HP DS OUED
2,16	↓	
21,33	<p>SUMMIT</p>	ET P //
0,23		

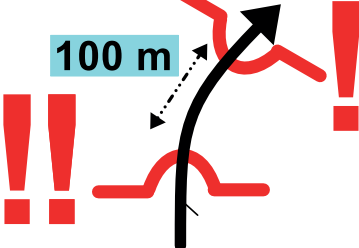
Next 5,72

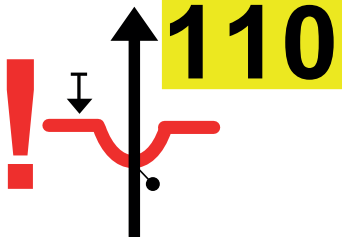
◀ MODÈLE DE ROAD BOOK / ROAD BOOK MODEL ▶

4	/ Présentation RB V5 /	Km : 31,16
27,05		
5,72 		
30,06		
3,01 		
<u>30,59</u>		 !! P W W
0,53		
31,16		 !! P W W
0,57		

Next



odc
ORGANISATION
DAVIDCASTERA
EVENTS

2019

RALLYE DU MAROC

FES • ARFOUD • FES



OFFICIAL SPONSOR



INSTITUTIONAL PARTNER



OFFICIAL SUPPLIER

